



230_{VAC}

BILL30M

LINEAR TELESCOPIC OPERATOR

personalised release key

up to 2.5 m



CONTROL UNITS:

BILL30M — BRAINY HEADY

BENINCA

100%
Made in Italy



230 Vac

- Irreversible 230 Vac electromechanical geared motor with easy access release from above
- Neat design and size, particularly suited to forged iron gates
- Easy and quick to install due to compact size and installation geometry
- Worm protected by a scraper ring and stainless steel stem, suitable for use in dusty and sandy environments or where there are aggressive atmospheric agents
- Available in right or left version

www.beninca.com

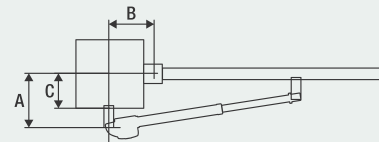
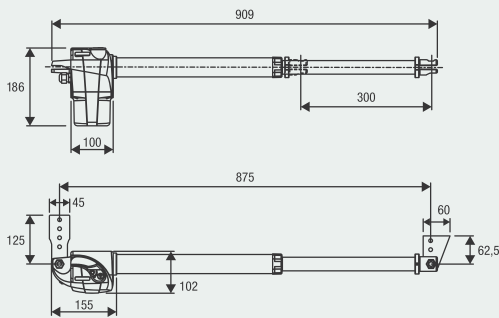

A (mm)	B (mm)	C (mm)
100-150	100-150	60-100

BENINCA

COMPLETE KITS

MOTORS	CONTROL UNIT	PHOTOCELLS	FLASHING LIGHT	SELECTOR	TRANSMITTER
KBILL30M	2x BILL30M	1x HEADY	1x PUPILLA.R	1x LAMPI.LED	1x TOKEY
					1x TO.GO2VA



B.SR
Multiposition brackets for one operator.

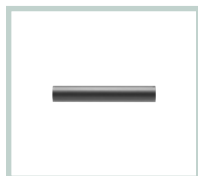

BILL30.CO
Telescopic stem cover accessory.



DU.V96
12 Vac/dc vertical electric lock, supplied with counterplate. Permits internal/external release.



DU.V90
12 Vac/dc horizontal electric lock, supplied with counterplate. Permits internal/external release.

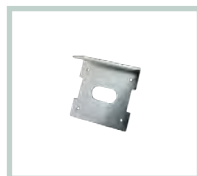

DU.9990
Covering plate for DU.V90.



E.LOCK
230 Vac vertical electric lock, supplied with counterplate.



E.LOCKSE
Extended cylinder for E.LOCK electric lock. It allows unlocking gates up to 55mm-thick from the outside.



ID.TA
Warning board.



IRI.TX4VA
4-channel transmitter with Advanced Rolling Code and Rolling Code.



IRI.TX4AK
4-channel transmitter with Advanced Rolling Code and Fixed Code.



IRI.LAMP
White full range flashing light, 20-255 VAC with built-in aerial.



IRI.KPAD
Battery operated wireless vandal-proof digital keypad with alert buzzer and backlit buttons. Triple coding: Rolling Code, Programmable Code and Advanced Rolling Code. 254 memorisable codes.



IRI.CELL
Pair of vandal-proof metal covers for PUPILLA/PUPILLA.R photocells, comprising front and rear shells with concealed screw. They can maintain perfect orientation over 180°.



PUPILLA
Pair of photocells adjustable to 180°. Option to synchronise up to 4 pairs, 24 VAC/DC power supply. Easy adjustment through a LED that signals optimal alignment. Compact size: 36x110x35 mm

AUTOMATISMI BENINCÀ SpA • Via del Capitello, 45 • 36066 Sandrigo (VI) ITALY • T +39 0444 751030 • sales@beninca.com

TECHNICAL DATA	BILL30M*
Power supply	230 Vac (50-60Hz)
Motor supply	230 Vac
Max absorbed current	1.1 A
Max Thrust	2800 N
Opening time	16"
Duty cycle	30%
Standard stroke	300 mm
Max stroke	320 mm
Protection level	IP54
Operating temperature	-20°C /+50°C
Leaf max dimension	2.5 m
Weight	6.1 kg
Items no. per pallet	62
Kit weight	14.6 kg
Kits no. per pallet	40

* Available in 115 VAC version