

L8543208
10/2016 rev 1

IRI.KPAD.C

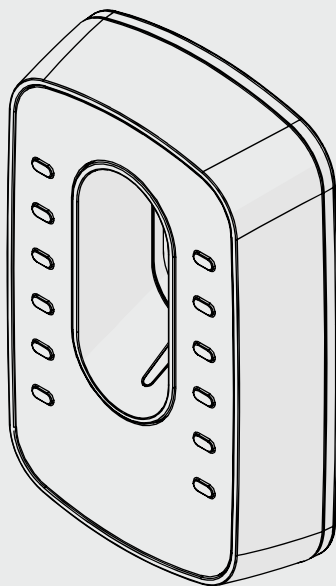

BENINCA[®]
TECHNOLOGY TO OPEN

UNIONE NAZIONALE COSTRUTTORI
AUTOMATISMI PER CANCELLI, PORTE
SERRANDE ED AFFINI



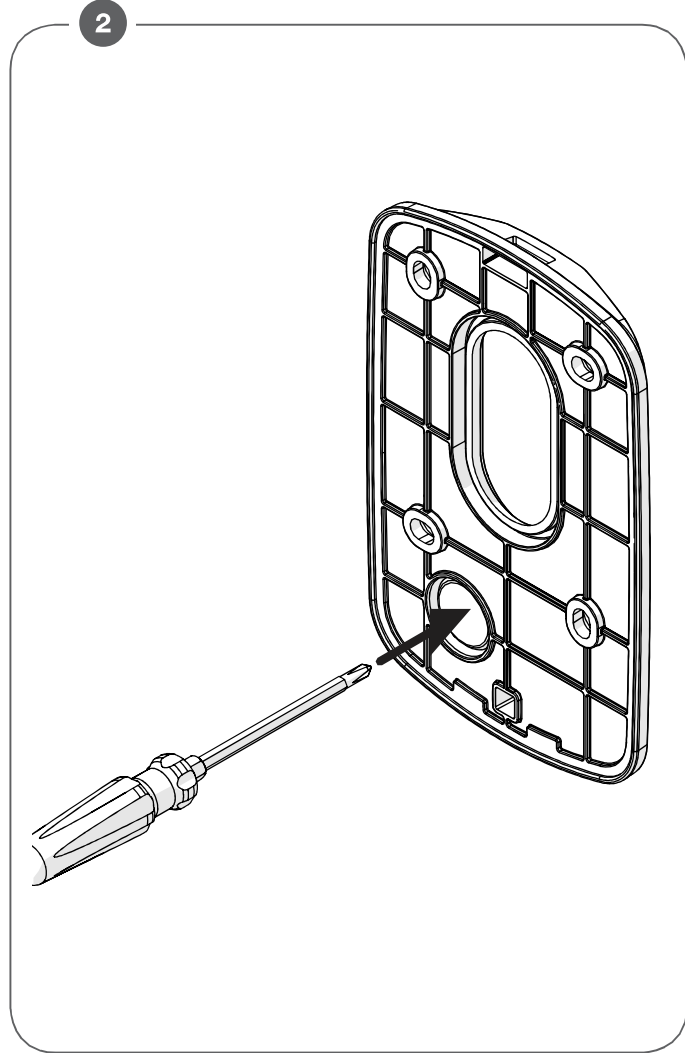
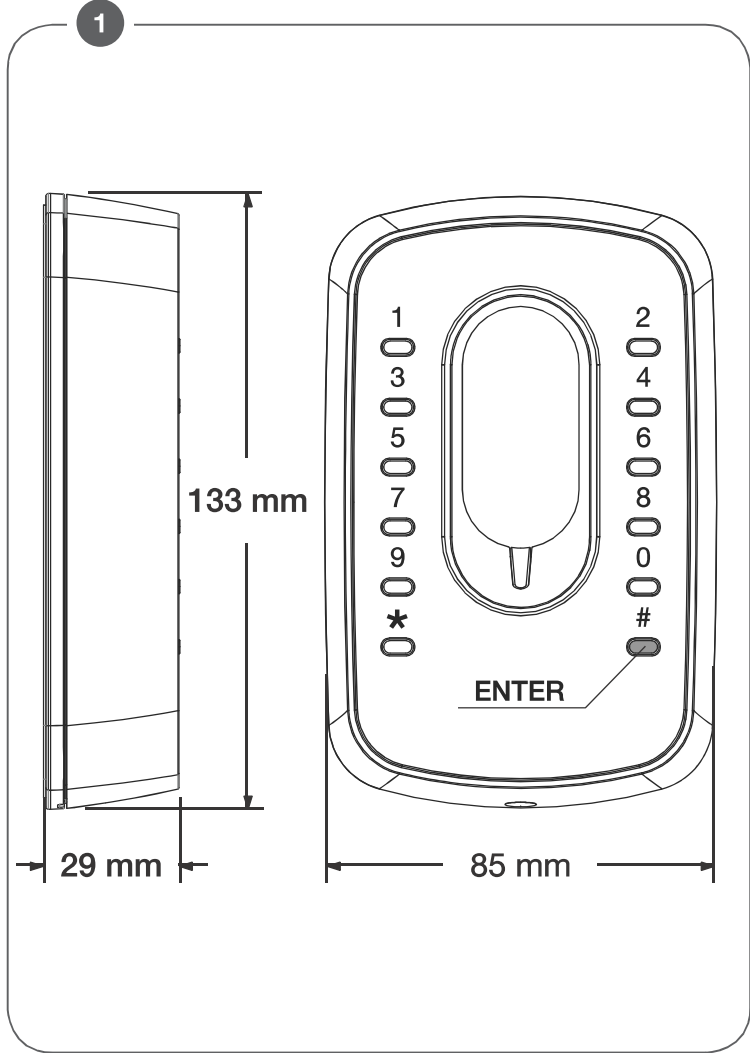

3

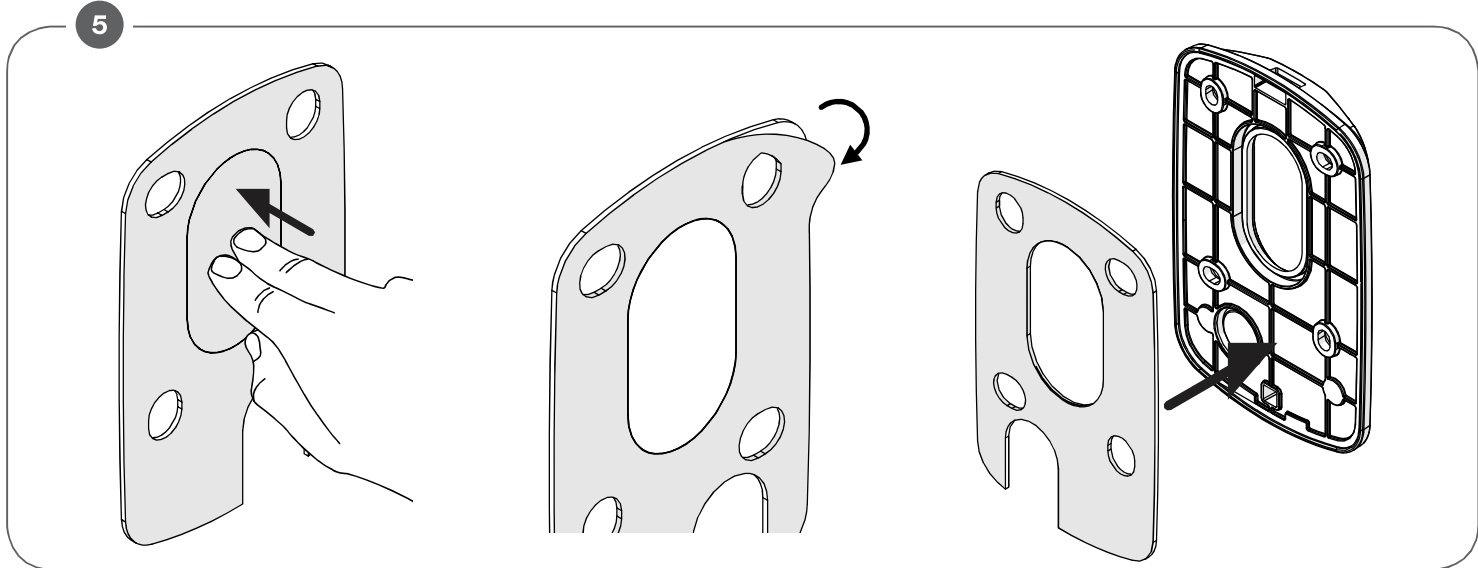
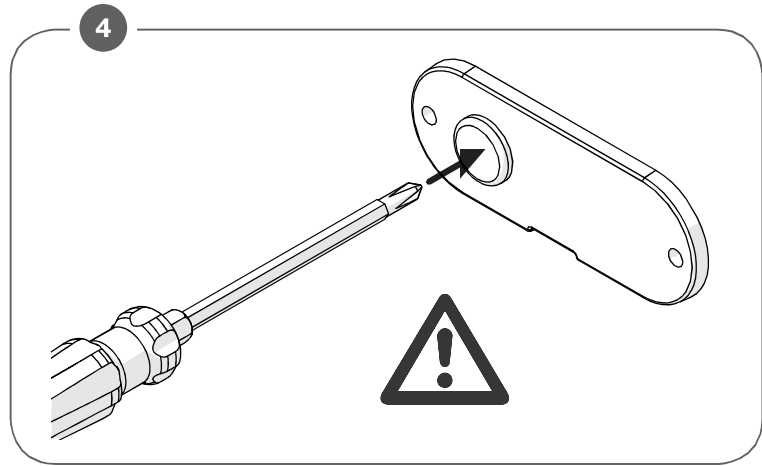
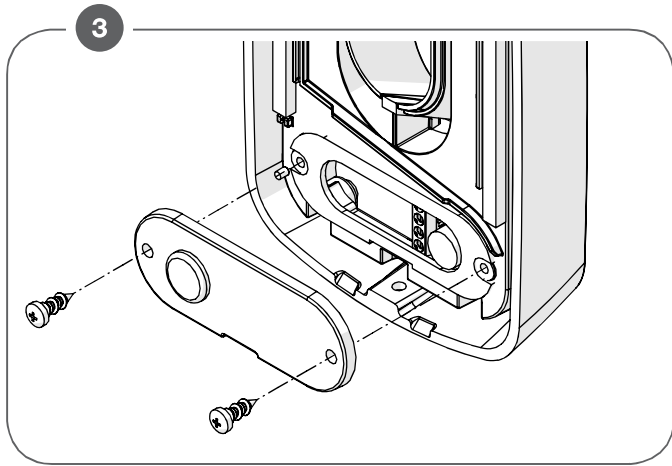

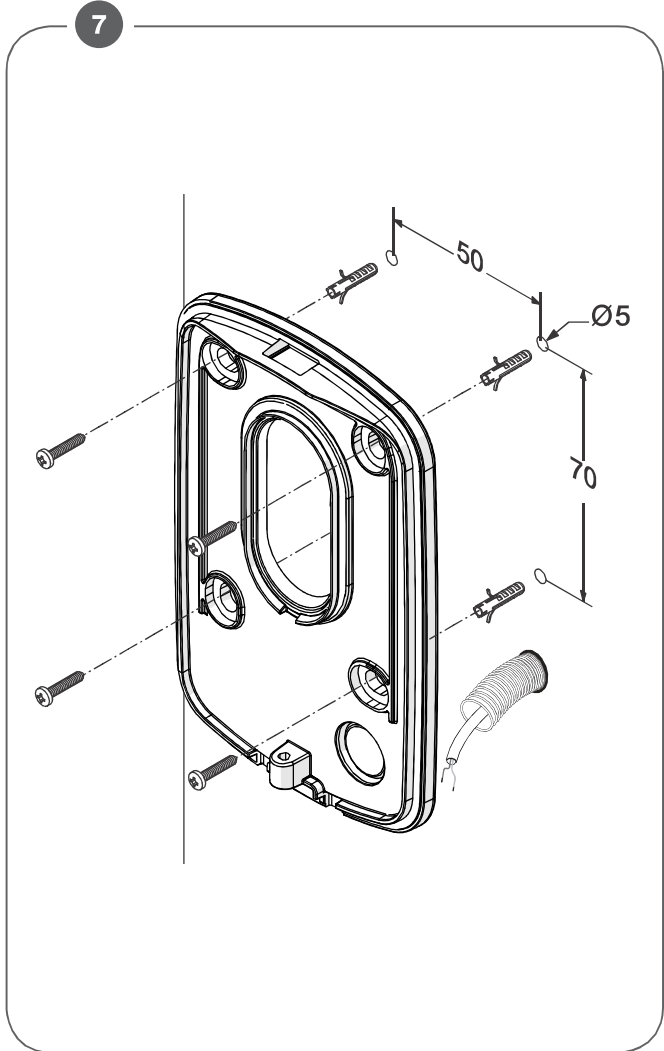
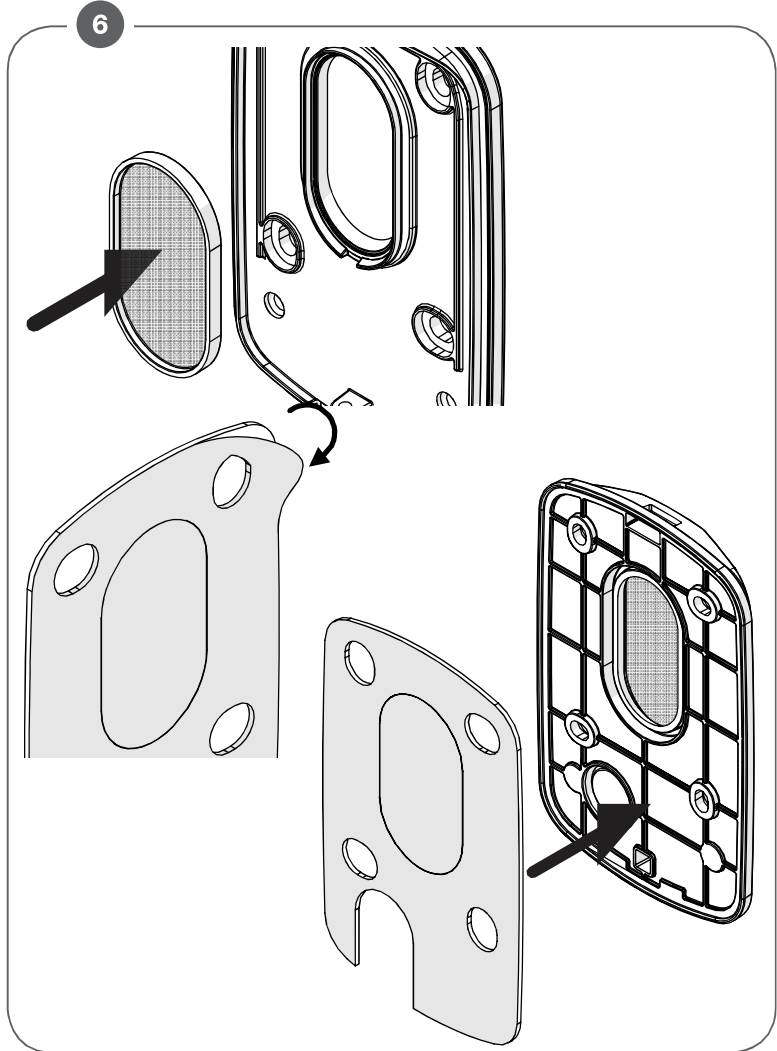

5

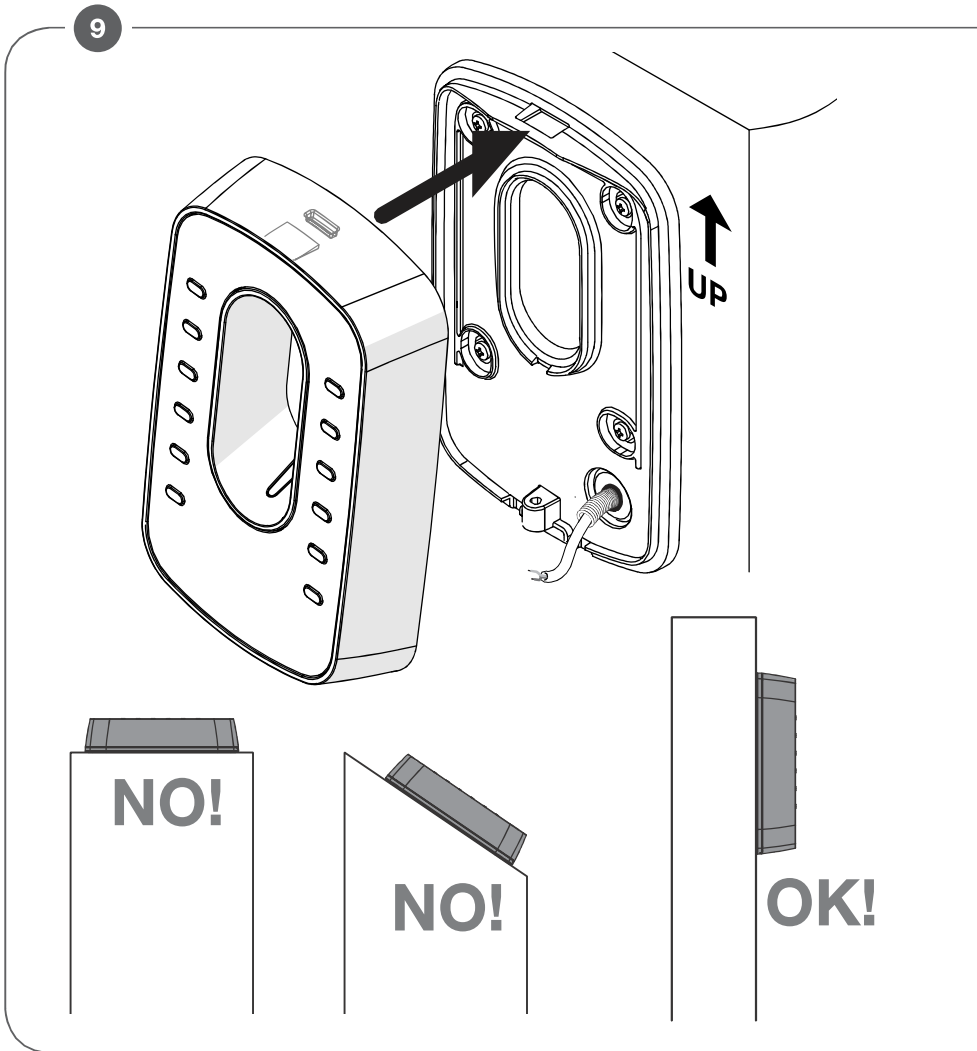
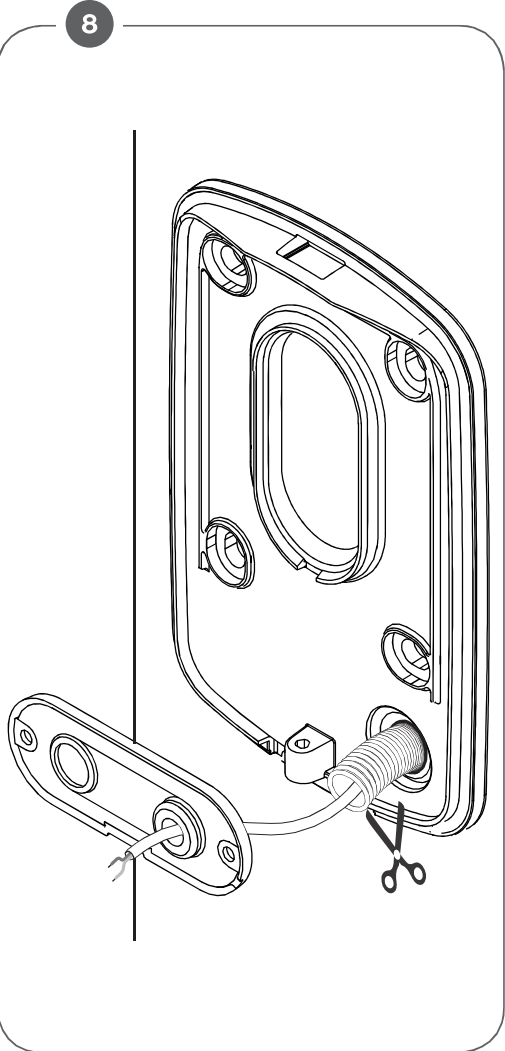

6

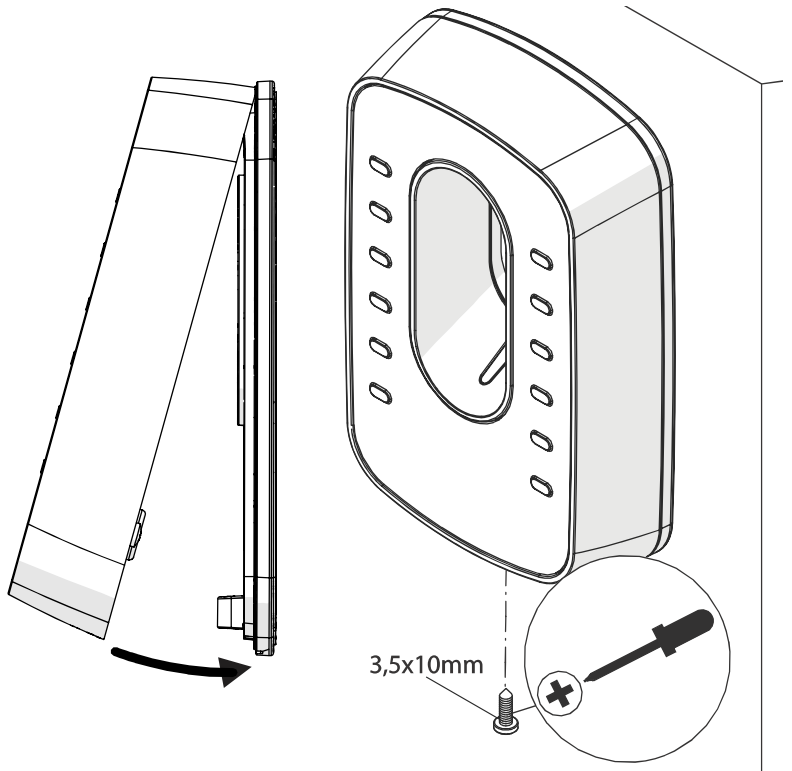

10

STAND-ALONE MODE

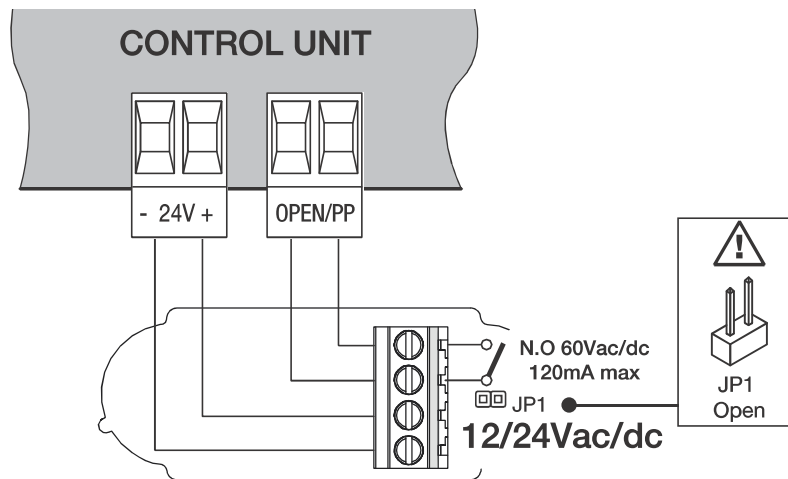

11

STAND-ALONE + POWER MODE

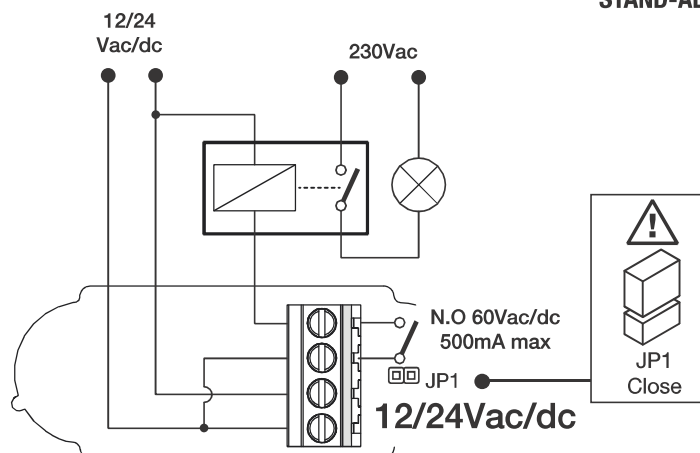

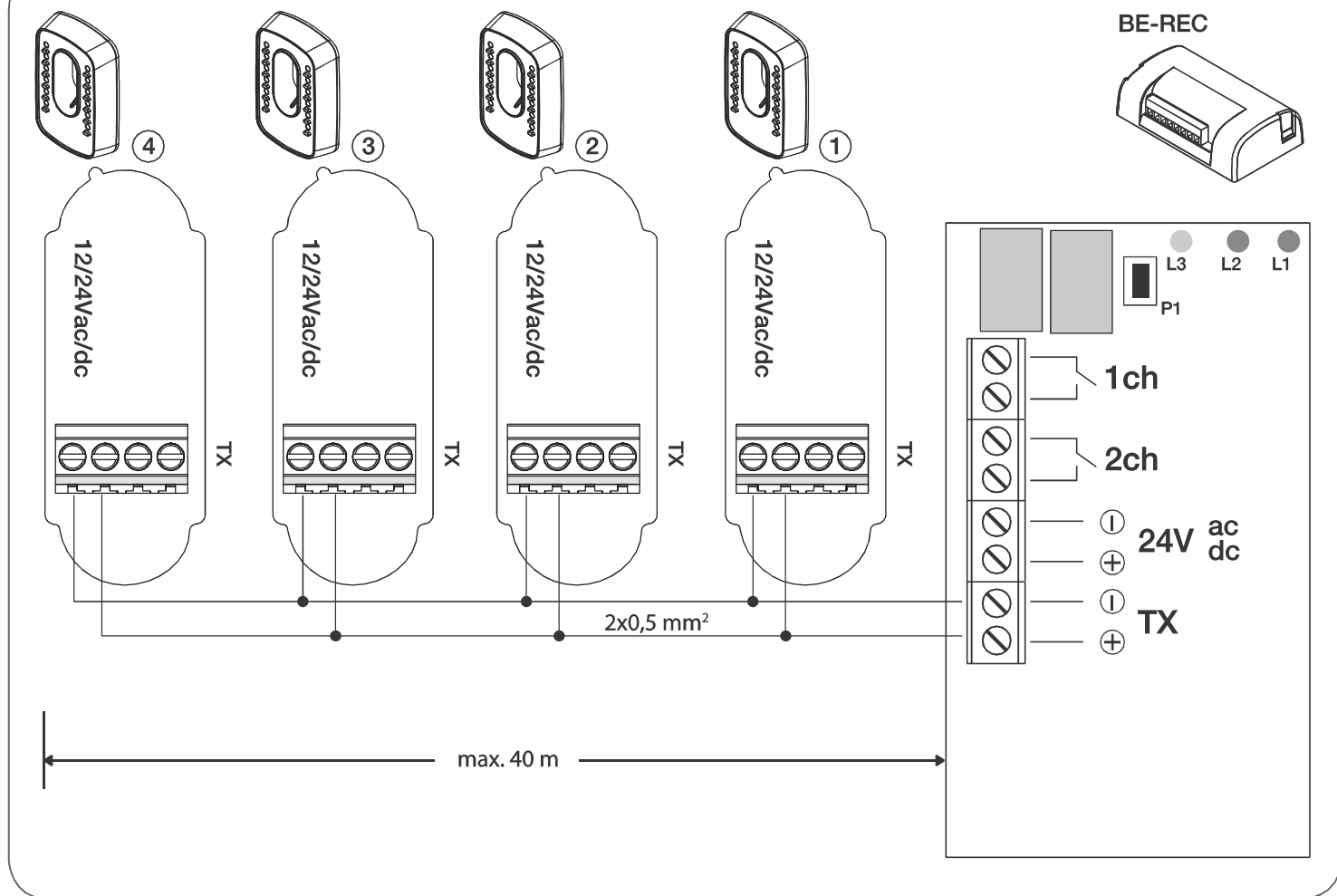

ENG

WARNING



The product shall not be used for purposes or in ways other than those for which the product is intended for and as described in this manual. Incorrect uses can damage the product and cause injuries and damages.

The company shall not be deemed responsible for the non-compliance with a good manufacture technique of gates as well as for any deformation, which might occur during use. Keep this manual for further use.



This manual has been especially written to be use by qualified fitters. Installation must be carried out by qualified personnel (professional installer, according to EN 12635), in compliance with Good Practice and current code. Make sure that the structure of the gate is suitable for automation. The installer must supply all information on the automatic, manual and emergency operation of the automatic system and supply the end user with instructions for use.



Packaging must be kept out of reach of children, as it can be hazardous. For disposal, packaging must be divided the various types of waste (e.g. carton board, polystyrene) in compliance with regulations in force.

Do not allow children to play with the fixed control devices of the product. Keep the remote controls out of reach of children.

This product is not to be used by persons (including children) with reduced physical, sensory or mental capacity, or who are unfamiliar with such equipment, unless under the supervision of or following training by persons responsible for their safety.

Apply all safety devices (photocells, safety edges, etc.) required to keep the area free of impact, crushing, dragging and shearing hazard. Bear in mind the standards and directives in force, Good Practice criteria, intended use, the installation environment, the operating logic of the system and forces generated by the automated system. Installation must be carried out using safety devices and controls that meet standards EN 12978 and EN 12453. Only use original accessories and spare parts, use of non-original spare parts will cause the warranty planned to cover the products to become null and void.

All the mechanical and electrical parts composing automation must meet the requirements of the standards in force and outlined by CE marking.



An omnipolar switch/section switch with remote contact opening equal to, or higher than 3mm must be provided on the power supply mains.

Make sure that before wiring an adequate differential switch and an overcurrent protection is provided.

Pursuant to safety regulations in force, some types of installation require that the gate connection be earthed.

During installation, maintenance and repair, cut off power supply before accessing to live parts.

Also disconnect buffer batteries, if any are connected. The electrical installation and the operating logic must comply with the regulations in force.

The leads fed with different voltages must be physically separate, or they must be suitably insulated with additional insulation of at least 1 mm.

The leads must be secured with an additional fixture near the terminals.

During installation, maintenance and repair, interrupt the power supply before opening the lid to access the electrical parts.

Check all the connections again before switching on the power. The unused N.C. inputs must be bridged.



WASTE DISPOSAL

As indicated by the symbol shown, it is forbidden to dispose this product as normal urban waste as some parts might be harmful for environment and human health, if they are disposed of incorrectly. Therefore, the device should be disposed in special collection platforms or given back to the reseller if a new and similar device is purchased. An incorrect disposal of the device will result in fines applied to the user, as provided for by regulations in force.

Descriptions and figures in this manual are not binding. While leaving the essential characteristics of the product unchanged, the manufacturer reserves the right to modify the same under the technical, design or commercial point of view without necessarily update this manual.

1) IRI.KPAD.C

1.1) DESCRIPTION

Programmable Digital Keypad to control gate and similar mechanisms. It can be used in two different ways:

STAND-ALONE MODE:

Requires a power supply of 12/24 Vac/dc, avails of 1 N.O. contact to command a control unit or other device. Entering a valid numerical code sends a code that activates the output contact.

If necessary, you can use an auxiliary relay for direct control of a mains voltage device. In this case, ensure the type of relay used is compatible with the power supply voltage of IRI.KPAD. Refer to Fig. 10/11.

REMOTE MODE:

Requires connection to a BE.REC device (Fig.12). All the codes are saved in the BE.REC device memory. Entering a valid numerical code sends an encrypted code to the BE.REC receiver, the code, if validated, leads to relay 1 or 2 switching according to the setting. As a result, the use mode of the IRI.KPAD.C guarantees greater safety and flexibility compared to use of the built-in N.O. contact.

Refer to Fig.12 for connection to the BE.REC* device.

Use of the BE.REC receiver enables use of certain advanced functions described in the BE.REC manual:

- insertion of codes to scale
- deletion of a code
- deletion of all codes with a specific initial digit
- re-enabling of all codes with a specific initial digit
- re-enabling of all disabled codes

* Install BE.REC in a safe place, not accessible from outside

Other characteristics:

- LED back-lighting.
- Code composition from 4 to 9 digits.
- Number of keys from 0 to 9 plus confirmation key #.
- Possibility of setting the access password, the codes to scale and elimination of individual codes.
- Buzzer for sound indications.

17

1.2) TECHNICAL DATA

Power supply	12/24 Vac/Vdc in stand-alone mode
Absorption (Stand-alone mode)	10 mA
Working temperature	-20°C / +70°C
Number of codes saved	30 STAND-ALONE MODE codes 254 REMOTE MODE codes
Level of protection	IP54
Dimensions	see Fig.1

1.3) WALL MOUNTED INSTALLATION (FIG. 2)

IRI.KPAD.C can be applied to the wall using the screws and plugs indicated in Fig.7.

- 1) Use a screwdriver to open the prepared cable passage section on the wall support (Fig.2)
- 2) Remove the cover protecting the terminal board and open the prepared cable passage section with a screwdriver (Fig.3/4).

ATTENTION! Make a same sized hole as the cable to avoid water infiltration. If necessary, seal with silicone.

- 3) Apply the adhesive gasket on the back of the wall support.

Note: The central part of the keypad can be removed to leave the part beneath in view. In this case, remove the central part of the gasket and apply it to the support having removed the central cover (Fig.5).

Alternatively, leave the closure cover in position and apply the entire adhesive gasket Fig. 6.

- 4) Fasten the support to the wall (Fig.7), with screws and plugs according to the type of support.
- 5) Pass the connection cables through the openings (Fig.8)
- 6) Install the connections with reference to the "Electrical connections" paragraph.
- 7) Rest the IRI.KPAD.C on the support and fasten it with the screw (Fig.9).

The level of protection IP54 also enables outdoor use. However, application is preferred to a protected wall.

IRI.KPAD.C can only be installed on vertical walls, respecting the instructions in the previous points. Outdoor installation is not permitted on horizontal or tilted supports (Fig.9).

1.4) ELECTRICAL CONNECTION

STAND ALONE MODE:

NB: Having powered the device, wait 10 seconds for led switch on (device initialization).

In Fig.10 in IRI.KPAD.C the N.O. output is connected to the input in low safety voltage and OPENS a control unit, in this case leaving Jumper JP1 open.

In Fig. 11 a support relay is used that guarantees electrical separation, in this case it is important to close the JUMPER JP1 and comply with the maximum voltage and current values on contact indicated in Figure 10.

REMOTE MODE:

Figure 12 indicates the BE.REC receiver connection.

You can connect up to 4 IRI.KPAD.C to a single BE.REC receiver,

in this case you need to separately power the IRI.KPAD.C devices and the Jumper JP1 is irrelevant.

For all the information relating to configuration of the BE.REC receiver, refer to the instruction specifications.

FAST USER'S GUIDE

2) STAND-ALONE MODE - PROGRAMMING

2.1) SAVING A CODE

- 1 Type the access password (123456 preset password), followed by (#).
- 2 Type 1.
- 3 Type the saving code (from 4 to 9 digits) and press (#)
- 4 The buzzer emits 2 beeps to confirm programming.
- 5 The code is now saved.

2.2) DELETING A CODE

- 1 Type the access password (123456 preset password), followed by (#).
- 2 Type 2, the buzzer emits 2 beeps.
- 3 Type the code to delete and press (#)
- 4 The buzzer emits 2 beeps to confirm deletion.

19

2.3) COMPLETE DELETION OF THE MEMORY

- 1 Type the access password (123456 preset password), followed by (#).
- 2 Type 9, the buzzer emits 3 beeps.
- 3 Type the reset password (1234567890) and press (#).
- 4 The buzzer intermittently sounds until resetting is complete.
- 5 The device is now brought back to the manufacturing conditions, all the codes have been removed.

2.4) PERSONALISATION OF ACCESS PASSWORD

- 1 Type the access password 123456 preset, followed by (#).
- 2 Type 6, the buzzer emits 2 beeps.
- 3 Type the new, personal password (6 digits) and press (#), the buzzer emits 3 beeps.
- 4 Confirm the new password by typing it a second time and press (#)
- 5 The buzzer emits 2 beeps to confirm the operation is complete.

3) REMOTE MODE - PROGRAMMING

IMPORTANT: In REMOTE mode, programming of the various functions takes place on the BE.REC receiver. Only the basic functions are outlined below.

To use the advanced functions refer to the BE.REC manual, the advanced functionalities are as follows:

- Insertion of codes to scale (up to 999 accesses)
- Disabling of all codes with a certain initial digit
- Re-enabling of all codes with a certain initial digit
- Re-enabling of all disabled codes

3.1) SAVING CODES

- 1 Press the PGM button once on the BE.REC receiver. The LED starts to flash.
- 2 Type the code to save (minimum 4, maximum 9 digits), on each pressing the buzzer emits a sound to confirm typing.
- 3 Press the key (#), the buzzer emits a prolonged sound.
- 4 On the keypad, select the channel (relay) on the BE.REC receiver you intend associating the code with, keeping in mind that:
 - typing "1" you activate channel 1.
 - typing "2" you activate channel 2.
 - typing "3" you activate both channels (1+2).
- 5 Press the key (#), the buzzer emits three beeps to confirm programming.
- 6 The code is now saved and will activate the channel selected in point 4.

3.2) DELETING A CODE

- 1 Press the PGM button twice on the BE.REC receiver. The LED starts to flash with a frequency of 2 flashes followed by a pause.
- 2 On the keypad type the code to delete, on each pressing the buzzer emits a sound to confirm typing.
- 3 Press the key (#), the buzzer emits three beeps to confirm deletion.

3.3 COMPLETE DELETION OF THE MEMORY

- 1 Press and keep the PGM button pressed on BE.REC for 15s. The red and green LEDs initially off flash alternatively, when flashing finishes the deletion is also complete.
- 2 Having deleted the receiver return to the timed output settings of 1s and the access password in advanced mode 123456.

