

ProAccess

Vehicle detection sensor for gates and barriers

Original operating instructions

General

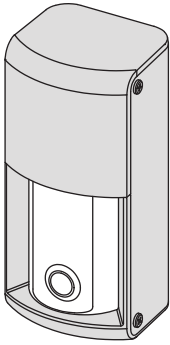

Dimensions

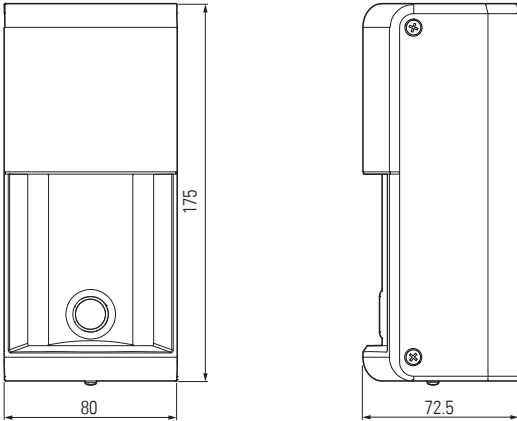

(Further details see chapter 3)

Sensor unit

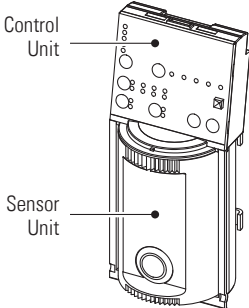

Control unit

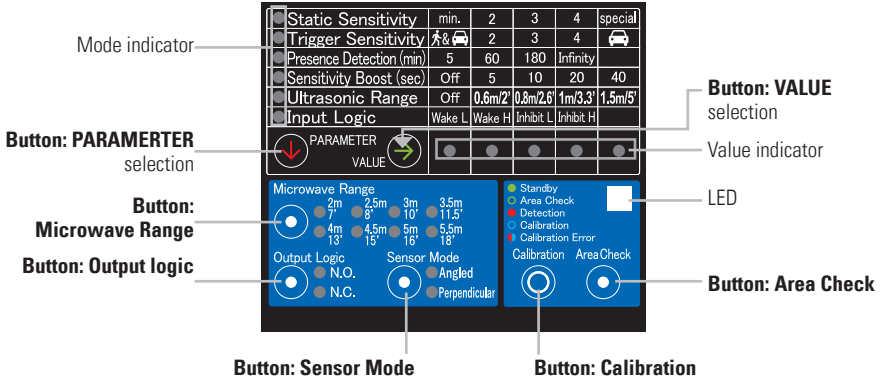

Static Sensitivity	min.	2	3	4	special	
Trigger Sensitivity		2	3	4		
Presence Detection (min)		5	60	180	Infinity	
Sensitivity Boost (sec)		Off	5	10	20	40
Ultrasonic Range		Off	0.6m/2'	0.8m/2.6'	1m/3.3'	1.5m/5'
Input Logic		Wake L	Wake H	Inhibit L	Inhibit H	

1 Safety instructions



- Read these operating instructions thoroughly before putting the device into operation and keep them for future reference.
- This product is a vehicle detection sensor designed to detect approach and presence of a vehicle in proximity of a gate or barrier.
- Do not use this product other than for its specified application.
- The assembly, commissioning, modifications and extensions may only be completed by an experienced electrician!
- Pay attention to all local relevant electrical safety regulations!
- Failure to follow these safety precautions may cause damage to sensor or objects, serious personal injury, or death.
- It is the responsibility of the equipment installer to carry out a risk assessment and to install the system, in compliance with applicable local, national and international regulations, safety standards, codes and laws as well as the Machinery Directive 2006/42/EC, should this apply.
- Observe all applicable local, national, and international door safety standards, codes, and laws.
- Always consider the safety functions of your applications as a whole, never just in relation to one individual section of the system.
- The installer is responsible for testing the system to ensure it meets all applicable safety standards.
- During the operation of electrical components – e. g. in the case of a short

circuit hot and ionised gases can be emitted; protection covers must not be removed!

- The device should only be operated from a safety extra low voltage (SELV) system with safe electrical separation according to EN 61558. The wiring must be protected against mechanical damage.

Prior to starting installation or mounting, take the following safety precautions:

- Check the voltage data on the label of the sensor.
- Ensure that the device/installations cannot be switched on!
- Ensure that the power supply is disconnected!
- Protect the device with a housing against contamination or harsh environments!
- Protect the sensor against rain and snow.
- Disconnect device from mains in the event of a fault.
- Avoid touching any electronic and optical components.
- The door drive and the transom must be properly earthed.
- After accessing the inside of the device, ensure the cover/protection seal is closed tightly to achieve designated protection rating.
- Ensure the commercial door operator has all of its monitored entrapment protection devices installed and operational. This sensor does not replace any entrapment protection devices.
- Limited protection against accidental contact!

2 Sensor installation recommendations

The sensor will not work correctly unless the height, direction and sensor mode are set correctly.

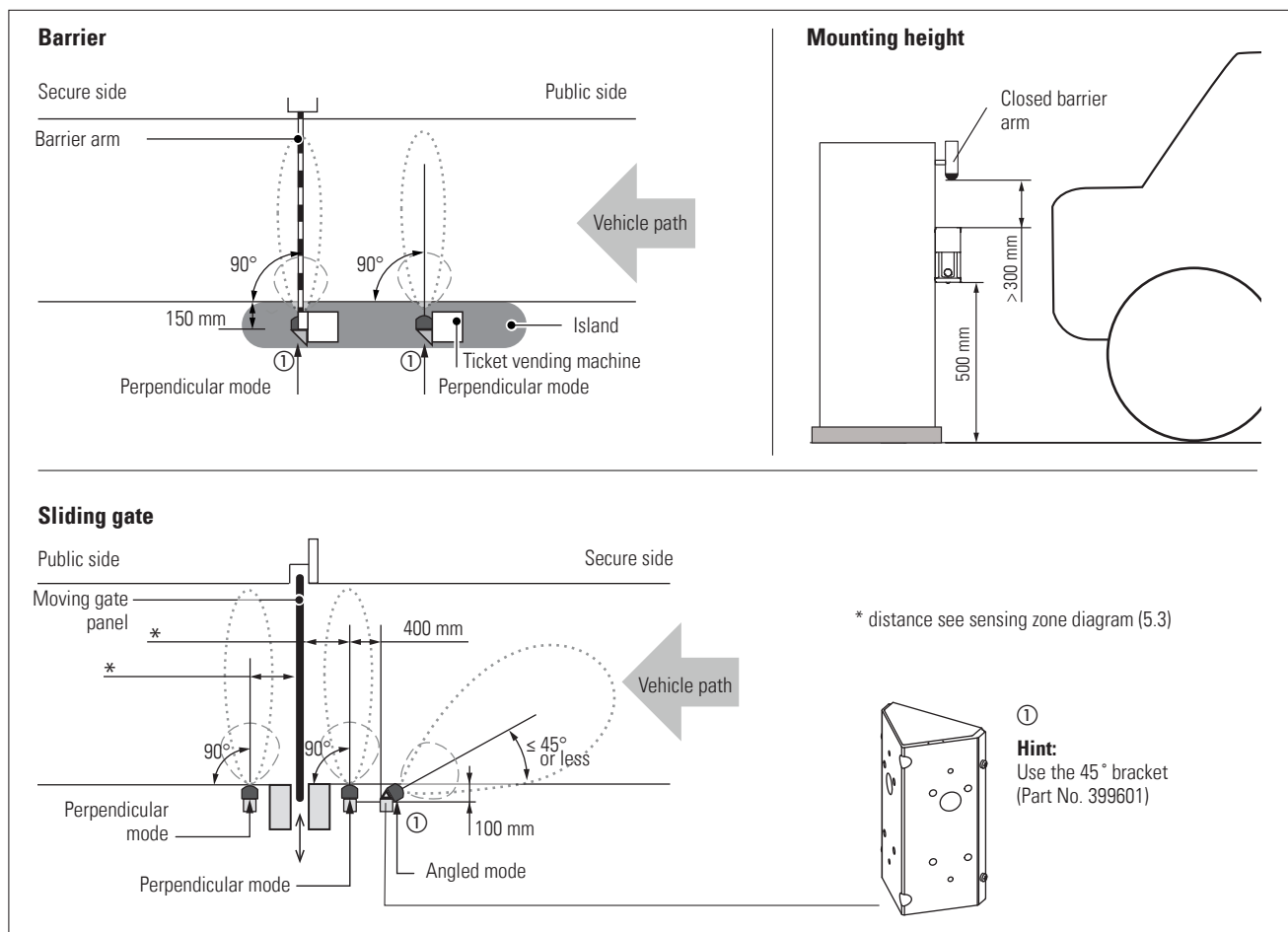

i Notes:

Please make adjustment to ensure the detection plane is parallel to the road surface. Some vertical adjustment may be required if the road surface rises or falls.

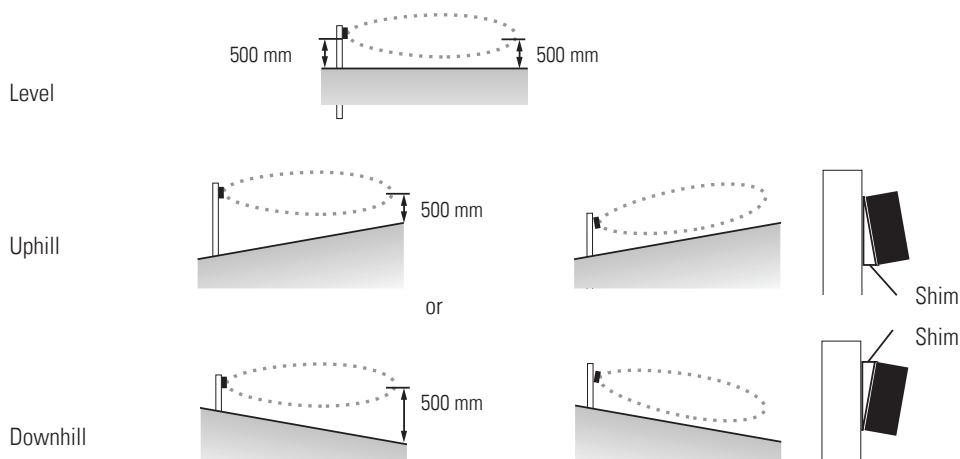

Do not install any moving object such as flags or banners within the sensing zone. Remove any vegetation from sensing zone, or reconfigure the sensing zone to be smaller.	Not following these steps may prevent the sensor to leave the state of detection or delay the change of the state.
Do not place an object such as a signboard close to the sensor's detection area.	
Make sure there is no irregularity on the ground within the sensing zone.	
Do not use a fluorescent lamp around the detection area.	It may prevent proper operation of the sensor.
A barrier arm with a skirt or placard may cause unstable detection by the sensor.	In such a case, remove the placard or relocate the sensor to prevent such issue.

3 Installation of the unit

Required tools:

- Precision screwdriver, Phillips #1
- Screwdriver, Phillips #2

1

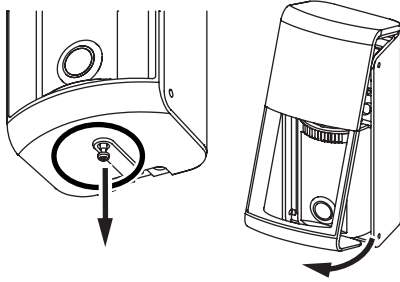

Loosen the retaining screws on the bottom of the front cover and remove the front cover.
(Do not loosen the screw completely. The screw may fall out. If the screw is lost, use a M3 x 10 Philips screw.)

2

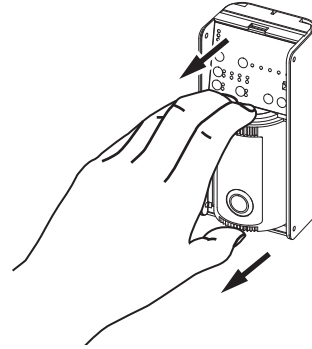

To detach the sensor unit:
Hold here and pull forward

3

Drill holes.
Route cable.

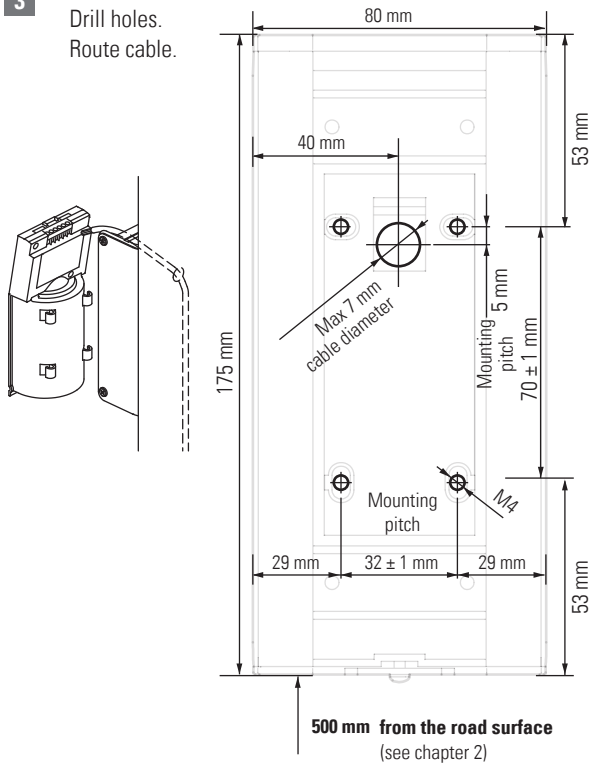

4

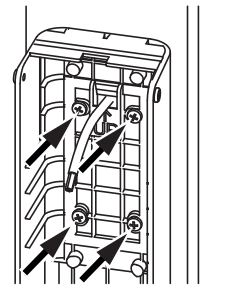

Attach the base to the mounting surface using 4 screws.

5 Connect wires to the terminals.

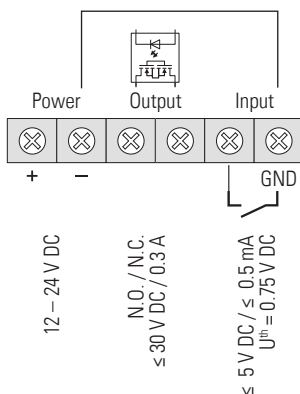

wire cross section:
solid 0.5 – 1.2 mm²
stranded 0.3 – 2.0 mm²

6

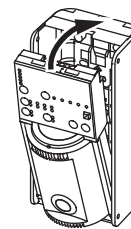

Push the sensor unit back into the base. Push the excess wire (≥ 10 cm) back into the mounting surface.

→ Setup
see page 4

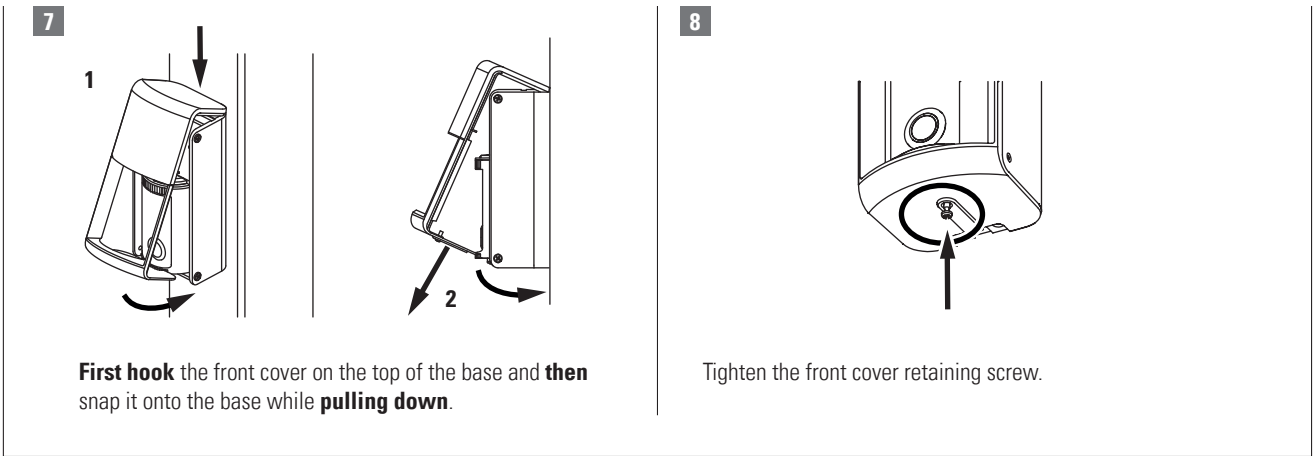

4 Setup

Rotate the sensor unit to the correct angle.

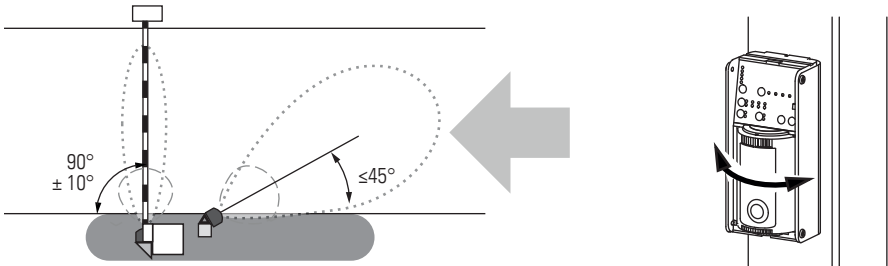

Sensor Mode Configure the proper sensor mode by pressing and holding the **Sensor Mode button** for 2 seconds.

Factory setting: Perpendicular

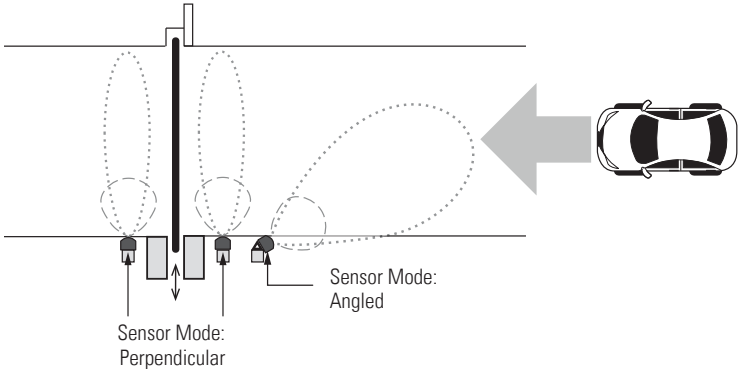

Output Select the output logic type (by pressing the **Output Logic button**).

Factory setting: N.O.

Microwave Range Adjust the detection range (by pressing the **Microwave Range button**).
Recommendation: Set the range 500 mm shorter than the actual width of the road.

Factory setting: 3.5 m

4.1 Calibration

Calibration memorizes the background of the detection area → perform without any pedestrians or vehicle present!

- Press and hold the **Calibration button** on the sensor unit for 2 seconds and verify that the LED is blinking slowly in blue. The LED blinks for 8 seconds and blinks more quickly for 2 seconds.
- If the ultrasonic sensor detects an object during calibration, the LED blinks in red and blue alternately, resulting in calibration error. If the cause cannot be eliminated reduce the range.
- When the calibration is complete, the LED turns solid green.
- If a noticeable change occurs around the detection area (such as construction of a wall or fence), the calibration must be performed again.
- If a vehicle or pedestrian enters the detection area during the calibration, perform the calibration again.
- If a change is made to the sensor installation height, direction angle, and/or Microwave Range perform the calibration again.

4.2 Detection area check (can be performed after calibration)

Press the **Area Check button**

The LED blinks green.

- If there is a pedestrian or an object in the detection area, the LED lights up:
 - Blinking yellow: Only the microwave sensing element is detecting
 - Blinking purple: Only the ultrasonic sensing element is detecting
 - Blinking red: Both the microwave and the ultrasonic are detecting
- If requested:
 - adjust the ultrasonic sensor range
 - 1. Press the **MODE button** and select Ultrasonic Range
 - 2. Press the **VALUE button** and select the desired sensing distance
- After 30 seconds without detection it will automatically change back to the normal operation mode.

Factory setting:
1 m

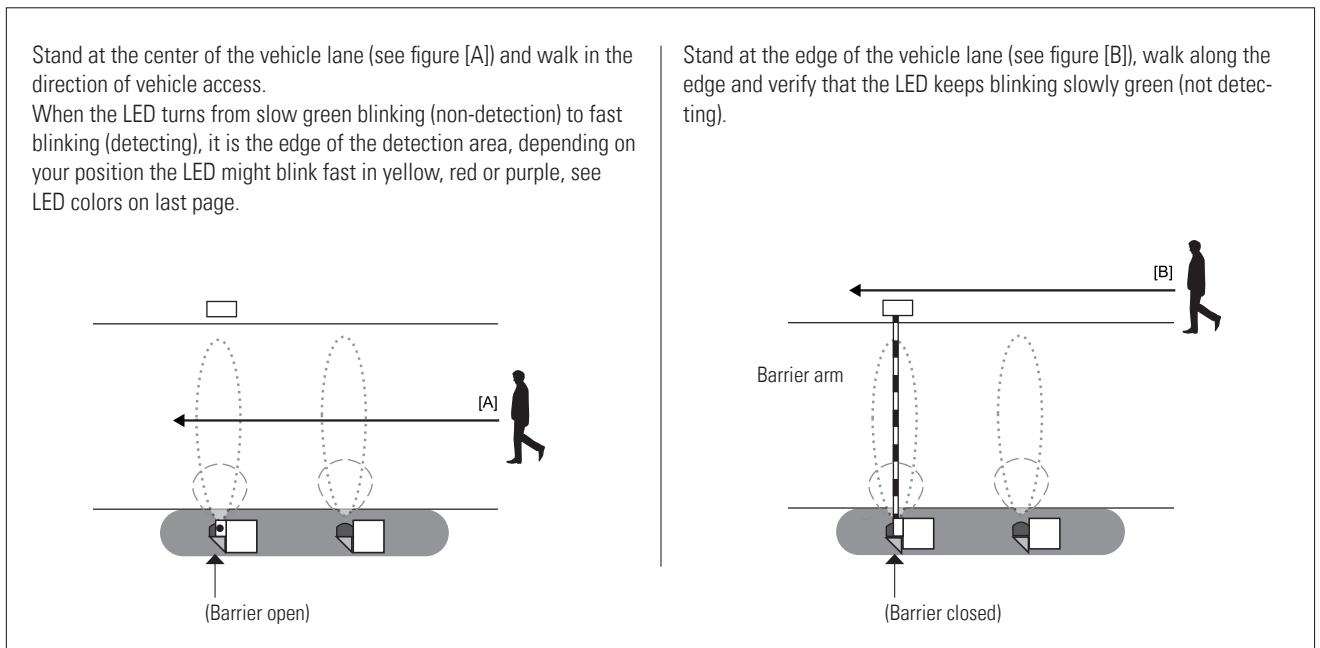

After verifying the detection area: Press the **Area check button** again

4.3 System operation check

After verifying the detection area, check the entire system using a vehicle.
For this purpose, approach with a vehicle over the full width of the driveway.

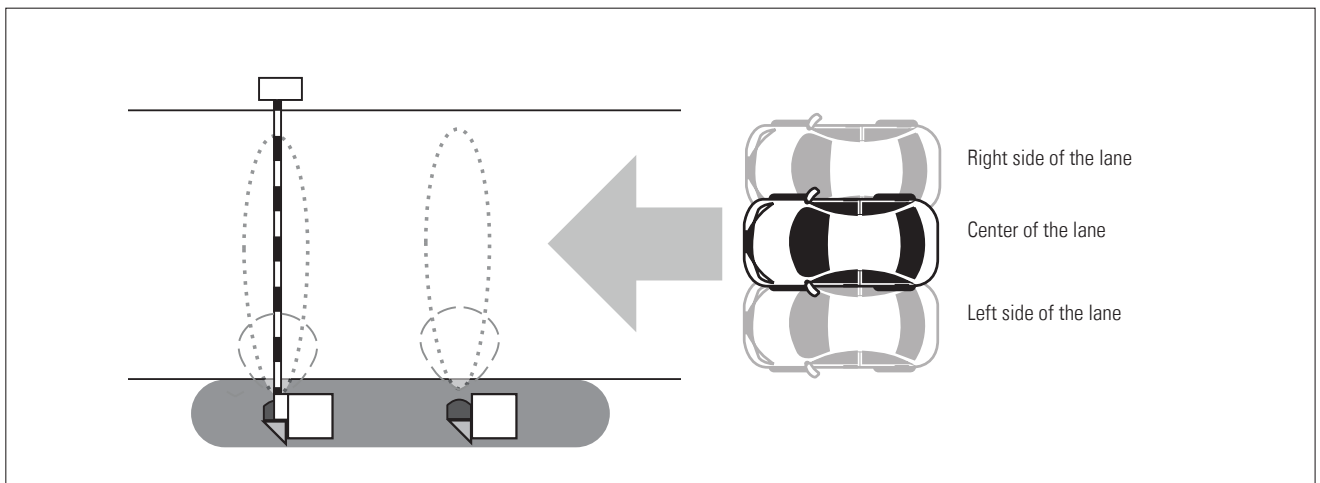

For advanced settings (if needed): → go to page 6

5 Advanced settings

All these parameters are to be adjusted if the sensor does not operate as expected. They are not necessary for a normal installation.

5.1 Trigger sensitivity

● Static Sensitivity	min.	2	3	4	special
● Trigger Sensitivity	人&车	2	3	4	车
● Presence Detection (min)	5	60	180	Infinity	
● Sensitivity Boost (sec)	Off	5	10	20	40
● Ultrasonic Range	Off	0.6m/2'	0.8m/2.6'	1m/3.3'	1.5m/5'
● Input Logic	Wake L	Wake H	Inhibit L	Inhibit H	
PARAMETER	VALUE	●	●	●	●

Factory setting:
3

- Increase** the value if:
- A person is detected occasionally
 - The sensor detects a vehicle passing close to (but not within) the detection area
- Decrease** the value if:
- Occasionally a vehicle is not detected
 - Response of detection is too slow

5.2 Static sensitivity (after initial detection)

● Static Sensitivity	min.	2	3	4	special
● Trigger Sensitivity	人&车	2	3	4	车
● Presence Detection (min)	5	60	180	Infinity	
● Sensitivity Boost (sec)	Off	5	10	20	40
● Ultrasonic Range	Off	0.6m/2'	0.8m/2.6'	1m/3.3'	1.5m/5'
● Input Logic	Wake L	Wake H	Inhibit L	Inhibit H	
PARAMETER	VALUE	●	●	●	●

Factory setting:
3

- Increase** the value if: Occasionally a vehicle presence is not held or the detection response is too slow
- Decrease** the value if: The sensor stays in detection after a vehicle has left

Note: Once the level is set to special, the sensor will trigger to any type of object (see chapter 5.1).

5.3 Sensing zone diagram

Top view

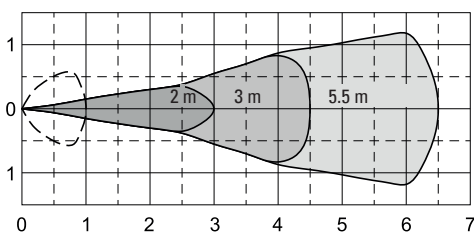

Side view

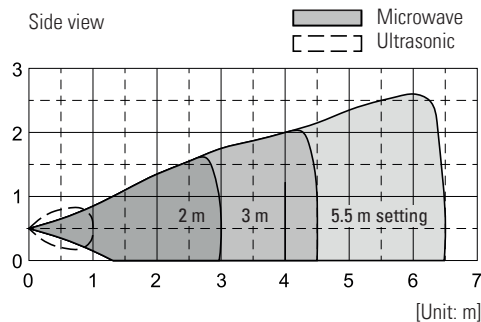

5.4 Presence detection

The sensor periodically performs re-calibration. This can prevent the sensor from permanently staying switched on. If any of the following conditions is fulfilled, change the presence detection value:

- The sensor keeps detecting due to an object in the detection area.
- The sensor keeps detecting after installing a roadblock.

Factory setting:
5 min.

Description:

- An object is placed in the detection field of the microwave area and the sensor detects the object.
- When the presence timer has run out, the sensor changes to non-detection state because the object is memorized as a background.
- When the object is removed, the sensor may stay in a non-detection or detection state.
- If the sensor stays in the non-detection state, it may be less sensitive for a while.
- When the object is removed after the time period of presence detection, the sensor will memorize again the background and be in non-detection state.

5.5 Sensitivity boost

Use only with perpendicular mode.

Factory setting:
Off

The sensitivity boost enhances the sensitivity for a certain period of time after a vehicle has passed through the detection area. Enable this function if a vehicle may back up unintentionally due to a slope in the exit area.

- While the sensitivity boost is enabled, a human or an object other than a vehicle may be detected.
- The function cannot be used for a gate system without a reopen function.

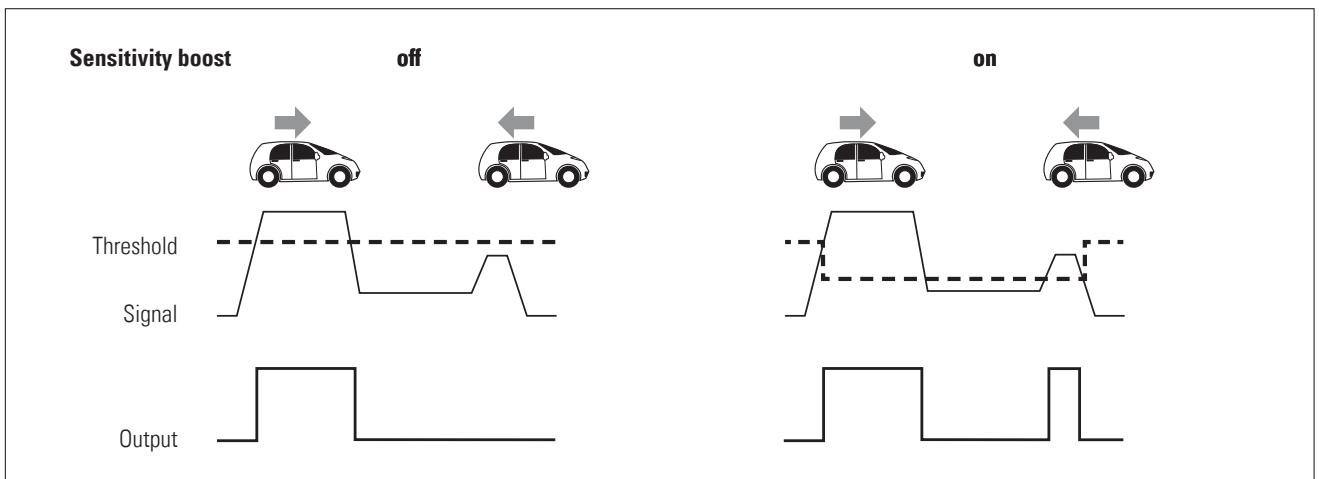
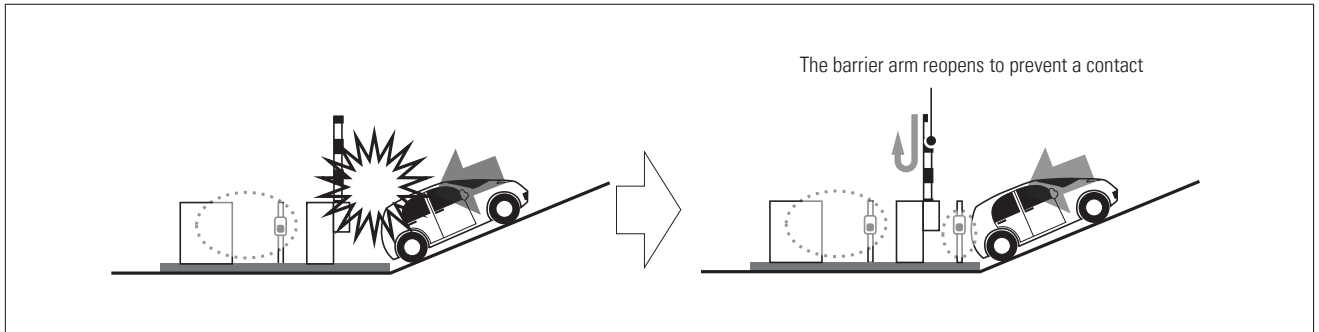

5.6 Input

Use INHIBIT to deactivate output e.g. while swing gate is moving into sensing zone.
Use WAKE to detect any object within the sensing zone similar to light beam.

Factory setting:
Wake L

5.7 Factory reset

Press and hold both the **Calibration button** and **Area Check button** at the same time for 2 seconds.

6 LED signals / troubleshooting

LED ^{x)}		Mode	Indication	Output	
Colour	Solid / blinking			logic NO	logic NC
none	off	Unpowered		open	open
green	solid	Standard operation	Standby	open	CLOSED
green	blinking twice	Standard operation	Large metal object present (best remove)	open	CLOSED
green	blinking	Detection Area Check	Outside detection area	open	CLOSED
yellow	blinking	Detection Area Check	Within microwave detection area	CLOSED	open
yellow	solid 2 seconds	Factory reset	Reset completed	open	CLOSED
red	solid	Standard operation	Detection	CLOSED	open
red	blinking	Detection Area Check	Within microwave & ultrasonic detection area	CLOSED	open
purple	blinking	Detection Area Check	Within ultrasonic detection area	CLOSED	open
blue	blinking slowly	Calibration	Preparation → leave detection area!	open	CLOSED
blue	blinking fast	Calibration	Calibrating	open	CLOSED
blue – red	alternate blinking	Calibration	Ultrasonic sensor detection error	CLOSED / open	CLOSED / open

^{x)} Status of Input will not affect LED

7 Technical data

Sensor technology	Microwave: 24 GHz, Ultrasonic: 56 kHz
Supply voltage	12 – 24 V DC, ±15%
Response time	500 ms
Power consumption Heater disabled Heater enabled	Up to 80 mA (at 24 V) Max. 200 mA (at 12 V)
Output	Solid state relay 30 V DC, 0.3 A resistive (N.O. / N.C. selectable)
Input	Use dry contact switch ≤ 5 V DC / ≤ 0.5 mA U th = 0.75 V DC
Sensing distance Microwave sensor Ultrasonic sensor	0.8 to 5.5 m (max. range adjustable) 0.1 to 1.5 m (max. range adjustable)

Detectable vehicle speed	2 – 20 km/h
Operating temperature	–30 °C to 50 °C
Operating relative humidity	95% max. (no condensation)
Protection class	IP65
Installation height	500 mm (distance from the road surface to the bottom of the unit)
Sensor angle adjustment	Left and right: ±30 degrees (5-degree steps)
Dimensions	175 x 80 x 72.5 mm
Weight	420 g
In the box	M4 mounting screws (4x), manual

8 EU Declaration of Conformity



See attachment

9 WEEE



Devices with this symbol must be treated separately during disposal. This must be done in accordance with the laws of the respective countries for environmentally sound disposal, processing and recycling of electrical and electronic equipment.

10 FCC approval



This device meets the requirements of Part 15 of the FCC regulations and the RSS-210 standard of Industry Canada.
Warning: Changes or modifications made to this device may void the FCC authorisation to operate this device.

11 Contact

BBC Bircher Smart Access, BBC Bircher AG, Wiesengasse 20, CH-8222 Beringen, www.bircher.com

Made in Japan